

IMO's Maritime Safety Committee Circular, MSC.1/Circ.1206/Revision1 - Measures to Prevent Accidents with Lifeboats - dated 11 June 2009 – Main text and Annex 2



Ref. T4/3.01

MSC.1/Circ.1206/Rev.1
11 June 2009

MEASURES TO PREVENT ACCIDENTS WITH LIFEBOATS

1 The Maritime Safety Committee, at its eighty-first session (10 to 19 May 2006), recalled that at its seventy-fifth session (15 to 24 May 2002), it had considered the issue of the unacceptably high number of accidents with lifeboats in which crew were being injured, sometimes fatally, while participating in lifeboat drills and/or inspections, and noted that most accidents fell under the following categories:

- .1 failure of on-load release mechanism;
- .2 inadvertent operation of on-load release mechanism;
- .3 inadequate maintenance of lifeboats, davits and launching equipment;
- .4 communication failures;
- .5 lack of familiarity with lifeboats, davits, equipment and associated controls;
- .6 unsafe practices during lifeboat drills and inspections; and
- .7 design faults other than on-load release mechanisms.

2 Pending further consideration of the problem, the Committee approved MSC/Circ.1049 on Accidents with lifeboats, to draw the attention of manufacturers, shipowners, crews and classification societies to the personal injury and loss of life that may follow inadequate attention to the design, construction, maintenance and operation of lifeboats, davits and associated equipment and urged all concerned to take necessary action to prevent further accidents with lifeboats. It invited Member Governments to:

- .1 bring the circular to the attention of their maritime Administrations, relevant industry organizations, manufacturers, shipowners, crews and classification societies;
- .2 take the necessary action to prevent further accidents with lifeboats pending the development of appropriate IMO guidance;
- .3 ensure that:
 - .3.1 on-load release equipment used on ships flying their flag is in full compliance with the requirements of paragraphs 4.4.7.6.2.2 to 4.4.7.6.5 of the LSA Code;
 - .3.2 all appropriate documentation for the maintenance and adjustment of lifeboats, launching appliances and associated equipment is available on board;

- .3.3 personnel undertaking inspections, maintenance and adjustment of lifeboats, launching appliances and associated equipment are fully trained and familiar with these duties;
 - .3.4 maintenance of lifeboats, launching appliances and associated equipment is carried out in accordance with approved established procedures;
 - .3.5 lifeboat drills are conducted in accordance with SOLAS regulation III/19.3.3 for the purpose of ensuring that ship's personnel will be able to safely embark and launch the lifeboats in an emergency;
 - .3.6 the principles of safety and health at work apply to drills as well;
 - .3.7 personnel undertaking maintenance and repair activities are appropriately qualified;
 - .3.8 hanging-off pennants should only be used for maintenance purposes and not during training exercises;
 - .3.9 all tests required for the design and approval of life-saving appliances are conducted rigorously, according to the Guidelines developed by the Organization, in order to identify and rectify any design faults at an early stage;
 - .3.10 the equipment is easily accessible for inspections and maintenance and is proven durable in harsh operational conditions, in addition to withstanding prototype tests; and
 - .3.11 the approving authorities or bodies pay close attention to proper workmanship and state-of-the-art possibilities when assessing equipment for approval; and
- .4 encourage shipowners, when undertaking maintenance and repair activities, to employ qualified personnel, preferably certified by the manufacturer.

3 Member Governments were further invited, while enforcing the provisions of SOLAS regulation IX/4.3, to ensure that the above issues are addressed through the Safety Management System of the company, as appropriate.

4 The Committee further recalled that, at its seventy-seventh session (28 May to 6 June 2003), recognizing the experience gained since the approval of the Guidelines on inspection and maintenance of lifeboat on-load release gear (MSC/Circ.614) at its sixty-second session (24 to 28 May 1993), and that the implementation of expanded and improved guidelines could contribute towards a reduction of the incidence of accidents with lifeboats, it had approved the Guidelines for periodic servicing and maintenance of lifeboats, launching appliances and on-load release gear (MSC/Circ.1093), superseding MSC/Circ.614. Taking into account subsequent amendments to SOLAS chapter III and the LSA Code, and having considered proposals by the fiftieth session of the Sub-Committee on Fire Protection, the Committee approved amendments to the Guidelines, and further noted that the guidance developed for lifeboats could also apply to the periodic servicing and maintenance of liferafts, rescue boats and fast rescue boats and their launching appliances and on-load release gear.

5 The Committee further recalled that, at its seventy-ninth session (1 to 10 December 2004), it had endorsed the intention of the Sub-Committee on Ship Design and Equipment, in cooperation with the Sub-Committee on Standards of Training and Watchkeeping, to develop further IMO guidance as envisioned in MSC/Circ.1049 and, accordingly, approved the Guidance on safety during abandon ship drills using lifeboats (MSC/Circ.1136), as set out in annex 2. The Committee further recalled that the Guidance developed for lifeboats has relevance, in general, for emergency drills with other life-saving systems and should be taken into account when such drills are conducted. In connection with MSC/Circ.1136, and recognizing the need to provide a basic outline of essential steps to safely carry out simulated launching of free-fall lifeboats in accordance with SOLAS regulation III/19.3.3.4, and having considered proposals by the forty-seventh session of the Sub-Committee on Design and Equipment, the Committee further approved the Guidelines for simulated launching of free-fall lifeboats (MSC/Circ.1137), as set out in the appendix to annex 2.

6 Having considered the need to update several of the circulars discussed above, and having considered proposals by the fiftieth session of the Sub-Committee on Fire Protection to consolidate the numerous circulars on the subject of measures to prevent accidents with lifeboats in order to better serve the mariner, the Committee approved Guidelines for periodic servicing and maintenance of lifeboats, launching appliances and on-load release gear and Guidelines on safety during abandon ship drills using lifeboats, as set out in annexes 1 and 2, respectively, to MSC.1/Circ.1206.

7 The Maritime Safety Committee, at its eighty-sixth session (27 May to 5 June 2009), approved amendments to the aforementioned Guidelines (annexes 1 and 2 to MSC.1/Circ.1206) concerning inspection and maintenance of lifeboats, launching appliances and on-load release gear, following the recommendations made by the Sub-Committee on Ship Design and Equipment, at its fifty-second session. The revised Guidelines are set out in annexes 1 and 2 to this circular.

8 Member Governments are invited to give effect to the annexed Guidelines as soon as possible and to bring them to the attention of shipowners, ship operators, ship-vetting organizations, ship personnel, surveyors, manufacturers and all others concerned with the inspection and maintenance of lifeboats, liferafts, rescue boats and fast rescue boats and their launching appliances and on-load release gear.

9 This circular supersedes MSC/Circ.1049, MSC/Circ.1093, MSC/Circ.1136, MSC/Circ.1137 and MSC.1/Circ.1206.

ANNEX 2

GUIDELINES ON SAFETY DURING ABANDON SHIP DRILLS USING LIFEBOATS

1 GENERAL

1.1 Introduction

1.1.1 It is essential that seafarers are familiar with the life-saving systems on board their ships and that they have confidence that the systems provided for their safety will work and will be effective in an emergency. Frequent periodic shipboard drills are necessary to achieve this.

1.1.2 Crew training is an important component of drills. As a supplement to initial shore-side training, onboard training will familiarize crew members with the ship systems and the associated procedures for use, operation and drills. On these occasions, the objective is to develop appropriate crew competencies, enabling effective and safe utilization of the equipment required by the 1974 SOLAS Convention. The time limits set out in SOLAS for ship abandonment should be considered as a secondary objective when conducting drills.

1.2 Drill frequency

Experience has shown that holding frequent drills furthers the goals of making the crew familiar with the life-saving systems on board their ships and increasing their confidence that the systems will work and will be effective in an emergency. Drills give the crew opportunity to gain experience in the use of the safety equipment and in cooperation. The ability to cope with an emergency and handle the situation, if the ship needs to be abandoned, needs to be well rehearsed. However, frequent crew changes sometimes make it difficult to assure that all on board have had the opportunity to participate in drills if only the minimum required drills are conducted. Therefore, consideration needs to be given to scheduling drills as necessary to ensure all on board have an early opportunity to become familiar with the systems on board.

1.3 Drills must be safe

1.3.1 Abandon ship drills should be planned, organized and performed so that the recognized risks are minimized and in accordance with relevant shipboard requirements of occupational safety and health.

1.3.2 Drills provide an opportunity to verify that the life-saving system is working and that all associated equipment is in place and in good working order, ready for use.

1.3.3 Before conducting drills, it should be checked that the lifeboat and its safety equipment have been maintained in accordance with the ship's maintenance manuals and any associated technical documentation, as well as noting all the precautionary measures necessary. Abnormal conditions of wear and tear or corrosion should be reported to the responsible officer immediately.

1.4 Emphasis on learning

Drills should be conducted with an emphasis on learning and be viewed as a learning experience, not just as a task to meet a regulatory requirement to conduct drills. Whether they are emergency drills required by SOLAS or additional special drills conducted to enhance the competence of the

crew members, they should be carried out at safe speed. During drills, care should be taken to ensure that everybody familiarizes themselves with their duties and with the equipment. If necessary, pauses should be made during the drills to explain especially difficult elements. The experience of the crew is an important factor in determining how fast a drill or certain drill elements should be carried out.

1.5 Planning and organizing drills

1.5.1 The 1974 SOLAS Convention requires that drills shall, as far as practicable, be conducted as if there was an actual emergency.* This means that the entire drill should, as far as possible, be carried out. The point is that, at the same time, it should be ensured that the drill can be carried out in such a way that it is safe in every respect. Consequently, elements of the drill that may involve unnecessary risks need special attention or may be excluded from the drill.

1.5.2 In preparing for a drill, those responsible should review the manufacturer's instruction manual to assure that a planned drill is conducted properly. Those responsible for the drill should assure that the crew is familiar with the guidance provided in the life-saving system instruction manual.

1.5.3 Lessons learned in the course of a drill should be documented and made a part of follow-up shipboard training discussions and planning the next drill session.

1.5.4 The lowering of a boat with its full complement of persons is an example of an element of a drill that may, depending on the circumstances, involve an unnecessary risk. Such drills should only be carried out if special precautions are observed.

2 ABANDON SHIP DRILLS

2.1 Introduction

It is important that the crew who operate safety equipment on board are familiar with the functioning and operation of such equipment. The 1974 SOLAS Convention requires that sufficiently detailed manufacturers' training manuals and instructions be carried on board, which should be easily understood by the crew. Such manufacturers' manuals and instructions should be accessible for everyone on board and observed and followed closely during drills.

2.2 Guidance to the shipowner

2.2.1 The shipowner should ensure that new safety equipment on board the company's ships has been approved and installed in accordance with the provisions of the 1974 SOLAS Convention and the International Life-Saving Appliances (LSA) Code.

2.2.2 Procedures for holding safe drills should be included in the Safety Management System (SMS) of the shipping companies. Detailed procedures for elements of drills that involve a special risk should be evident from workplace assessments adjusted to the relevant life-saving appliance.

* Refer to SOLAS regulation III/19.3.1.

2.2.3 Personnel carrying out maintenance and repair work on lifeboats should be qualified accordingly.*

2.3 Lifeboats lowered by means of falls

2.3.1 During drills, those responsible should be alert for potentially dangerous conditions and situations and should bring them to the attention of the responsible person for appropriate action. Feedback and improvement recommendations to the shipowner, the Administration and the system manufacturer are important elements of the marine safety system.

2.3.2 When performing drills with persons on board a lifeboat, it is recommended that the boat first be lowered and recovered without persons on board to ascertain that the arrangement functions correctly. In this case, the boat should then be lowered into the water with only the number of persons on board necessary to operate the boat.

2.3.3 To prevent lashings or gripes from getting entangled, proper release should be checked before swinging out the davit.

2.4 Free-fall lifeboats

2.4.1 The monthly drills with free-fall lifeboats should be carried out according to the manufacturer's instructions, so that the persons who are to enter the boat in an emergency are trained to embark the boat, to take their seats in a correct way and to use the safety belts; and also are instructed on how to act during launching into the sea.

2.4.2 When the lifeboat is free-fall launched as part of a drill, this should be carried out with the minimum personnel required to manoeuvre the boat in the water and to recover it. The recovery operation should be carried out with special attention, bearing in mind the high risk level of this operation. Where permitted by SOLAS, simulated launching should be carried out in accordance with the manufacturer's instructions, taking due note of the Guidelines for simulated launching of free-fall lifeboats at appendix.

* Refer to the Guidelines for periodic servicing and maintenance of lifeboats, launching appliances and on-load release gear (see annex 1).

APPENDIX

GUIDELINES FOR SIMULATED LAUNCHING OF FREE-FALL LIFEBOATS

1 Definition

Simulated launching is a means of training the crew in the free-fall release procedure of free-fall lifeboats and in verifying the satisfactory function of the free-fall release system without allowing the lifeboat to fall into the sea.

2 Purpose and scope

The purpose of these Guidelines is to provide a basic outline of essential steps to safely carry out simulated launching. These Guidelines are general; the lifeboat manufacturer's instruction manual should always be consulted before conducting simulated launching. Simulated launching should only be carried out with lifeboats and launching appliances designed to accommodate it, and for which the manufacturer has provided instructions. Simulated launching should be carried out under the supervision of a responsible person who should be an officer experienced in such procedures.

3 Typical simulated launching sequence

3.1 Check equipment and documentation to ensure that all components of the lifeboat and launching appliance are in good operational condition.

3.2 Ensure that the restraining device(s) provided by the manufacturer for simulated launching are installed and secure and that the free-fall release mechanism is fully and correctly engaged.

3.3 Establish and maintain good communication between the assigned operating crew and the responsible person.

3.4 Disengage lashings, gripes, etc., installed to secure the lifeboat for sea or for maintenance, except those required for simulated free-fall.

3.5 Participating crew board the lifeboat and fasten their seatbelts under the supervision of the responsible person.

3.6 All crew, except the assigned operating crew, disembark the lifeboat. The assigned operating crew fully prepares the lifeboat for free-fall launch and secures themselves in their seats for the release operation.

3.7 The assigned operating crew activates the release mechanism when instructed by the responsible person. Ensure that the release mechanism operates satisfactorily and, if applicable, the lifeboat travels down the ramp to the distance specified in the manufacturer's instructions.

3.8 Resecure the lifeboat to its stowed position, using the means provided by the manufacturer and ensure that the free-fall release mechanism is fully and correctly engaged.

- 3.9 Repeat procedures from 3.7 above, using the back-up release mechanism when applicable.
 - 3.10 The assigned operating crew disembarks the lifeboat.
 - 3.11 Ensure that the lifeboat is returned to its normal stowed condition. Remove any restraining and/or recovery devices used only for the simulated launch procedure.
-

Extract from the Code of Safe Working Practices for Merchant Seamen -
Sections – 10.2 – 10.4.9 of Chapter 10 – Emergency Procedures

10.2 Musters and drills

10.2.1 Musters and drills are required to be carried out regularly in accordance with merchant shipping regulations. The guidance contained in this and the following sections should be read in conjunction with information and guidance on these regulations issued in the relevant Merchant Shipping Notices (MSNs, MGNs, MINs).

10.2.2 Musters and drills are designed to prepare a trained and organised response to dangerous situations which may unexpectedly threaten loss of life at sea. It is important that they should be carried out realistically, approaching as closely as possible to emergency conditions. Changes in the ship's function and changes in the ship's personnel from time to time should be reflected in corresponding changes in the muster arrangements.

10.2.3 The muster list must be conspicuously posted before the ship sails and, on international voyages and in ships of Classes IIA and III should be supplemented by emergency instructions for each crew member (eg in the form of a card issued to each crew member or affixed to individual crew berths and bunks). These instructions should describe the allocated assembly station, survival craft station and emergency duty and all emergency signals and action, if any, to be taken on hearing such signals.



10.2.4 An abandon ship drill and a fire drill must be held within 24 hours of leaving port if more than 25% of the crew have not taken part in drills on board the ship in the previous month. As soon as possible but not later than two weeks after joining the ship, onboard training in the use of the ship's life-saving appliances, including survival craft equipment, must be given to crew members. As soon as possible after joining the ship, crew members should also familiarise themselves with their emergency duties, the significance of the various alarm systems and the locations of their lifeboat station and of all lifesaving and fire fighting equipment.

10.2.5 All the ship's personnel concerned should muster/assemble at a drill wearing lifejackets properly secured. The lifejackets should continue to be worn during lifeboat drills and launchings but in other cases may be subsequently removed at the Master's discretion if they would impede or make unduly onerous the ensuing practice, provided they are kept ready to hand.

10.2.6 The timing of emergency drills should vary so that personnel who have not participated in a particular drill may take part in the next.

10.2.7 Any defects or deficiencies revealed during drills and the inspections which accompany them should be made good without delay.

10.3 Fire drills

10.3.1 Efficient fire-fighting demands the full co-operation of personnel in all departments of the ship. A fire drill should be held simultaneously with the first stage of the abandon ship drill. Fire-fighting parties should assemble at their designated stations. Engine room personnel should start the fire pumps in machinery spaces and see that full pressure is put on fire mains. Any emergency pump situated outside machinery spaces should also be started; all members of the crew should know how to start and operate the emergency pump.



10.3.2 The fire parties should be sent from their designated stations to the selected site of the supposed fire, taking with them emergency equipment such as axes and lamps and breathing apparatus. The locations should be changed in successive drills to give practice in differing conditions and in dealing with different types of fire so that accommodation, machinery spaces store rooms, galleys and cargo holds or areas of high fire hazard are all covered from time to time.

10.3.3 An adequate number of hoses to deal with the assumed fire should be realistically deployed. At some stage in the drill, they should be tested by bringing them into use, firstly with water provided by the machinery space pump and secondly with water provided by the emergency pump alone.

10.3.4 The drill should extend, where practicable, to the testing and demonstration of the remote controls for ventilating fans, fuel pumps and fuel tank valves, the closing of openings and the appropriate isolation of electrical equipment.

10.3.5 Fixed fire extinguishing installations should be tested to the extent practicable.

10.3.6 Portable fire extinguishers should be available for demonstration of the manner of their use. They should include the different types applicable to different kinds of fire. At each drill, one extinguisher or more should be operated by a member of the fire party, a different member on each occasion. Extinguishers so used should be recharged before being returned to their normal location or sufficient spares should otherwise be carried for demonstration purposes.

10.3.7 Breathing apparatus should be worn by members of the fire-fighting parties so each member in turn has experience of its use. Search



and rescue exercises should be undertaken in various parts of the ship. The apparatus should be cleaned and verified to be in good order before it is stowed; cylinders of self-contained breathing apparatus should be recharged or sufficient spare cylinders otherwise carried for this purpose.

MS
(Passenger
Ship
Construction
Ships of
Classes I, II
and II(A))
Regs 1998 -
SI 1998 No.
2514

10.3.8 In addition to the statutory inspection, fire appliances, fire and watertight doors, other closing appliances, and fire detection and alarm systems which have not been used in the drill should be inspected, either at the time of the drill or immediately afterwards.

10.4 Survival craft drills

MSN 1722
(M+F)

10.4.1 When arranging drills reference should be made to the relevant M Notice. Arrangements for drills should take account of prevailing weather conditions.

10.4.2 Crew members taking part in life-raft or lifeboat drills should muster wearing warm outer clothing and lifejackets properly secured.

10.4.3 Where appropriate, the lowering gear and chocks should be inspected and a check made to ensure that all working parts are well lubricated.

10.4.4 When turning out davits or when bringing boats or rafts inboard under power, seamen should always keep clear of any moving parts.

10.4.5 The engines on motor lifeboats should be started and run ahead and astern. Care should be taken to avoid overheating the engine and the propeller shaft stern gland. All personnel should be familiar with the engine starting procedure.

10.4.6 Hand-operated mechanical propelling gear, if any, should be examined and similarly tested.



10.4.7 Radio life-saving appliances should be examined and tested, and the crew instructed in their use.

10.4.8 Water spray systems, where fitted, should be tested in accordance with the lifeboat manufacturer's instructions.

MS (Musters, Training and Decision Support Systems) Regs 1999 - SI 1999 No. 2722 Reg 10 (6)

10.4.9 When a drill is held in port, as many as possible of the lifeboats should be cleared and swung out. Each lifeboat should be launched and manoeuvred in the water at least once every three months. Where launching of free-fall lifeboats is impracticable, they may be lowered into the water provided that they are free-fall launched at least once every six months. However, this may be extended to twelve months provided that arrangements are made for simulated launching which will take place at intervals not exceeding six months.

Reg 10 (7)



MCA's Instructions to Surveyors - MSIS 14 – Survey of Life-Saving Appliances Volume I - Section 18.3.5 – Bowsing and Tricing Arrangements and Appendix O and Annex 1 – Cordage for Life-saving Appliances

18.3.5 Bowsing and tricing arrangements

18.3.5.1 The general statutory requirements are in Regulations 28(15), 50(8), 50(9) and 71(8) and 71(9) of the Merchant Shipping (Life-Saving Appliances for Ships Other Than Ships of Classes III to VI(A)) Regulations 1999.

18.3.5.2 Surveyors should satisfy themselves that suitable means, independent of the davit turning out gear and having regard to the sizeweight of the loaded boats, are provided for keeping the lifeboats close to ship's side while the passengers are embarking and then releasing them under control when they are loaded preparatory to lowering. Where luffing davits are installed bowsing arrangements should be fitted, and where gravity davits are installed bowsing and tricing arrangements should be fitted.

18.3.5.3 Surveyors should ensure that gunwale fittings of lifeboat are not sited abreast the lifting hooks to avoid the possibility of tricing pendants catching up in fairleads, cleats or bollards. Such an occurrence could be dangerous or could cause serious delay in an emergency since the lifeboat may need to be lifted in order to clear the fouled wire.

18.3.5.4 The tricing pendant should only be used to bring the lifeboat into the ship's side when it has been lowered from the stowed position to the embarkation position. When the lifeboat is at the embarkation position the bowsing line or tackle should be fitted and secured and the tricing pendant slipped before boat embarkation commences. A hemp lashing should be provided at the bottom end of the tricing pendant and should be within reach of a man in the boat for cutting in emergency. Considering list and trim and the weight of 2 crew members to prepare the boat for embarkation the maximum working load of the tricing system should be taken as 1.2 times the weight of the light boat without persons and the system should have a safety factor of at least 4.5.

18.3.5.5 After the full complement of the lifeboat has embarked, the lifeboat should be eased out from the ship's side, preferably from inside the boat, by the bowsing lines or tackles to the plumb position for lowering. At the express wish of the master of a ship, this operation may be permitted from the deck of the ship in which case, for strength and stability, the lifeboat end of the bowsing tackles should be attached inside the boat to the special eye provided on the lower block.

18.3.5.6 The maximum working load on each bowsing line or tackle may, for all practical purposes, be taken as 2/5 the weight of the fully laden boat when the ship has a low side list of 20°; the bowsing lines or tackles should be of

sufficient length to control the boats until they are plumbed beneath the davit heads with the ship similarly listed. Bowsing blocks should have a minimum safety factor of 4.5.

18.3.5.7 Ropes used in bowsing lines or tackles should be of manila of good quality, or synthetic rope of equivalent strength, durability and grip which complies with a relevant BS EN standard (Appendix O). The property of grip is essential and the property of stretch should be minimal in this application.

18.3.5.8 The following table indicates the size of bowsing lines or tackles that might be accepted by gravity davits having a normal outreach giving a clearance between the ship's side and the side of the lifeboat of not more than 457 mm. The bowsing arrangements will need special consideration when this distance is exceeded.

Weight of boats fully laden	Tackle purchases	Size of rope (diam)	
		Manila	Synthetic
Under 10 tonnes	Two to one (luff) tackle	30 mm	24 mm
10 tonnes and under 12 tonnes	Two fold tackle	28 mm	24 mm
12 tonnes and under 15 tonnes	Three to two (gyn) tackle	28 mm	24 mm
15 tonnes up to max of 20 tonnes	Three to three tackle	28 mm	24 mm
Where tackles are used the blocks should be provided with hooks so that they may be placed in position and removed without delay.			

In addition to the rope and tackle bowsing systems mentioned above the MCA has accepted tailor made winch bowsing systems with wire rope for large lifeboats. Such special systems are dealt with on individual basis with detail calculations of structural stresses and prototype tests. Manufacturers should contact the nearest Regional Marine Office for approval of such specialised system for any particular ship.

APPENDIX O

NATURAL AND SYNTHETIC FIBRE CORDAGE FOR LIFE-SAVING APPLIANCES

1. Natural and synthetic ropes intended for use with life-saving appliances should be of a type which is acceptable to the MCA. Such ropes will incorporate a tape or similar throughout their length bearing at regular intervals:
 - (a) the initials or trade mark of the manufacturing company.
2. Before accepting a rope for use on board, the master should sight a certificate of conformity for the rope. In addition evidence showing that the rope is sufficiently protected and stabilized against UV degradation.
3. Responsibility for replacing worn, weathered or damaged cordage at all times lies with the master of the vessel.
4. Annex 1 "Cordage for LSA Purposes" indicates the characteristics required of ropes for various life-saving appliance uses and the sizes considered appropriate. Unlike natural cordage the grip provided by different types of synthetic fibre ropes ranges between a grip comparable with manila or sisal to little grip at all. The type of polypropylene cordage must therefore be carefully chosen to meet differing grip requirements.
5. Guidance on inspection and care of synthetic fibre ropes in use is included in Annex 2 'The inspection and care of polyamide (nylon), polyester and polypropylene filament ropes in use'.

ANNEX 1

CORDAGE FOR LIFE-SAVING APPLIANCES

Note: **M** denotes Manila rope, complying with BS EN 698: 1995-Fibre Ropes for General Service.

S denotes Sisal rope, complying with BS EN 698: 1995-Fibre Ropes for General Service.

Pa denotes Polyester rope complying with BS EN 697: 1995-Fibre Ropes for General Service (Polyester).

Pp denotes Polypropylene rope, complying with BS EN 699: 1995-Fibre Ropes for General Service (Polyporpylene).

All ropes to comply with the requirements of BS EN 701: 1995-Fibres Ropes for General Service General Specification. Where polypropylene is suggested and the grip is required to be similar to that of manila then only spun, staple polypropylene is suitable.

Application	Type	Grip	Minimum Size of Cordage Diameter in millimetres	
			M or S	Pa, Pe or Pp
Life Lifeboat and gunwale grablines	M S Pa Pe Pp	Not critical	16 mm	16 mm
Buoyant apparatus grablines	M S Pp	Not critical	14 mm	14 mm
Lifeboat keel grablines (should be knotted)	M S Pa Pe Pp	Not critical	16 mm	16 mm
Buoyant heaving lines	Cotton or Pp	As Manila	8 mm	8 mm
Lifeboat boarding ladders	M S Pa Pe Pp	As Manila	16 mm	16 mm
Overside ladders for lifeboat or liferaft embarkation	M Pa Pe Pp	As Manila	20 mm	20 mm
Lifebuoy grablines	M S Pp uninkable	Not critical	9.5 mm	9.5 mm
Lifebuoy lines	Buoyant Cotton Pp	As Manila	8 mm	8 mm
Lifelines from davit spans	M Pe Pp	As Manila	20 mm	24 mm
Boats' painters	M S Pa Pe Pp boat under 8 m	As Manila	20 mm	24 mm

Application	Type	Grip	Minimum Size of Cordage Diameter in millimetres	
			M or S	Pa, Pe or Pp
	8 m and under 9 m		24 mm	28 mm
	9 m boat and over		28 mm	32 mm
Buoyant apparatus painters	M S P	As Manila		
Mass less than 140 Kg			16 mm	16 mm
Mass 140 Kg and over			20 mm	20 mm
Sea anchor for open lifeboats of 6 metres and under	M S Pa Pe Pp	As Manila	Hawser: 20 mm Tripping Line: 12 mm	20 mm 12 mm
Open lifeboats over 6 metres			Hawser: 24 mm Tripping Line: 16 mm	24 mm 16 mm
Open lifeboat Sails: Halyards, sheets and roping	M S Pe Pp	As Manila	As current practice	As for natural fibre cordage
Bowsing tackle	Pe Pp	Should be of Manila or Polypropylene of a type acceptable to the MCA and having a grip comparable with Manila; the type and size of tackle and size cordage should be as follows:		
Fully laden mass of boat Under 8 tonnes	Purchase Gun (3 parts)			20 mm
8 tonnes and under 10 tonnes	Gun (3 parts)			24 mm
10 tonnes and under 12 tonnes	Luff (one double and single block)			18 mm
12 tonnes and under 15 tonnes	Two fold (two double blocks)			20 mm
15 tonnes and under 20 tonnes	Three/two fold (one treble and one double block)			20 mm
Boats' falls	Manila, durable, unkinkable, firm laid and pliable. Breaking load to be at least 6 x maximum load when hoisting and lowering. To be not less than 20 mm. To be able to pass freely a hole 10 mm larger than the nominal diameter of the rope. Man made fibre cordage is not generally accepted.			

mv *Saga Sapphire* - LSA Training Manual and Survival Techniques - Section 8.2 – Lifeboat Davits and Section 8.3 – Launching the Lifeboats

8.2 LIFEBOAT DAVITS

The MV Saga Sapphire is equipped with single pivot gravity davits that facilitate the launching of the Ships Lifeboats in the most extreme weather conditions, trim and list. Under SOLAS regulations all Lifeboats must be capable of being launched when the Ship has a 20⁰ list and a 10⁰ trim.

These davits work on the principle of the lifeboats own weight doing the work to bring about the launch. Once released, they will automatically swing outboard. The Gravity davits onboard are fitted with steel wire rope falls and operated by a control winch. The rate of decent of the boat is separately controlled by a centrifugal brake.



8.3 LAUNCHING THE LIFEBOATS

To launch the lifeboats, the procedure listed below should be followed,

1. **Release the Gripes** – All boats have 2/4 Gripes (sea lashings). The Gripes are secured around the hull of the lifeboat by the use of a quick release slip.
ENSURE THAT RIGGING SCREWS AND SLIP ARE CONTROLLED ON SLIPPING.
 2. **Remove the Battery charging plugs** on boats if fitted.
 3. **Lower the life boat to the embarkation level.** The winch controls are located on **10 Deck**. To lower the lifeboat, firstly ensure that all lashings are cleared away and then lift the brake handle upwards. To stop lowering simply lower the handle back down again.
 4. **Lower the lifeboat down until the weight comes onto the Trice-in pennants.** By allowing the weight to come onto the pennants, the lifeboat will be 'pulled' into the Ships side.
 5. **Two Crew members should then enter the Lifeboat.** Safe access can be gained by using the embarkation gates located in the Ships rails. **These crewmembers must don safety harnesses before boarding the boat. (See chapter 8 for further details).**
 6. Crew should then enter the lifeboat and carryout the following,
 - Insert the plugs into the Lifeboat hull.
 - Rig the Bows-in tackles. The tackles are colour coded, basically **RED** to **RED** and **WHITE** to **WHITE** to ensure the heaving part (tail) is inboard.
 7. **Let go of the Trice-in pennants.** On transferring the weight of the Lifeboat to the Bows-in tackles you can release the Trice-in pennants. Care should be exercised when releasing as there may still be some weight on the Pennants causing them to 'jump' when released.
 8. **Secure the Painter.** The Painter should be passed to Crew members onboard the Ship and secured by a round turn and two half hitches at the correct length.
 9. **Embark the Crew and passengers**
 10. **Release the Bowing – in tackles.** Once the lifeboat has been fully loaded, the Bows-in tackles may be paid out (let out) under control then released. Once they are clear, they should be passed to lifeboat for future use.
-

Written By: [REDACTED]

1st uncorrected copy. Positions, items and equipment may change as vessel is accepted into the Saga Fleet

11. Check below to ensure that all is clear, start and test the Engine. Instructions on how to start the Lifeboat engine can be found in Section 8.5. On completion of this the Boat can be lowered.
 12. Lower the lifeboat onto the crest of a wave.
 13. Unhook the falls.
 14. Embark the launching Crew via the embarkation ladder.
 15. Push bow off with a boat hook or oar.
 16. Let go/ release the toggle painter.
 17. Clear the Ship
-

Flag State Inspection report dated 17 March 2012 – Section 15 – Life-saving Appliances and
Section 18 – Additional Remarks/Comments/Deficiencies

SECTION 15 – LIFE-SAVING APPLIANCES

No.	Item	Port		Stbd		Remarks
		✓	x	✓	x	
1	Lifeboats	25 Enclosed Type freefall				
1.1	Hull in satisfactory condition and marking in place	✓			x	Last serviced March 2013
1.2	Becketed grab line & Grab rails and their attachment	✓		✓		
1.3	Lifting hook assembly & connection to hull satisfactory	✓		✓		
1.4	Limit switches operable	✓		✓		
1.5	Embarkation ladders, bousing-in tackles in good cond	✓		✓		
1.6	Launching instruct. Posted under emergency lighting	✓		✓		
1.7	LIFEBOAT ENGINE TEST: Starting time 2 min <input checked="" type="checkbox"/> Y <input type="checkbox"/> N	Vibration <input type="checkbox"/> Y <input checked="" type="checkbox"/> N		Ahead/Astern engage <input checked="" type="checkbox"/> Y <input type="checkbox"/> N		
2	Liferafts					
2.1	Inspection labels affixed on containers	✓		✓		Serviced June 2011 & Sept 11
2.2	Float-free arrangement/weak link correctly fitted	✓		✓		
2.3	Launching instruct. Posted under emergency lighting	✓		✓		
3	Rescue Boat	Port side boat missing				
4	Lifejackets 470+730 adults + children	Randomly checked and in good condition but see comm..				
5	Immersion Suits Last Serviced on Apr 10	30 In total. Randomly checked and in good condition				
6	Thermal Protective Aids	In good condition. Randomly seen in lifeboats				
7	Lifebuoys	12 In total and in good condition.				
8	Man Overboard (MOB)	Exp dates: Pt: 2014 Stbd: 2014				
9	EEBDs – Spares & training	Number: 7 spares + 1 training				

SECTION 18 - ADDITIONAL REMARKS /COMMENTS/ DEFICIENCIES

Vessel has / has not been allowed to leave port by order of the MMA and Master has been informed accordingly.

PSC on board: Y N Detained by PSC: Y N Class on board: Y N Others on Board: yes

Onboard during inspection : Class (GL)

Vessel is currently completing refurbishment works mainly on accommodation with 98% already completed and improvement works on engine room.

Operators have intentions to bring the vessel to Southampton in order to upgrade minor defects as well as completing jobs prior taking on passengers. Upon arrival to Southampton works will be carried out (schedule of works to be notified to Malta Transport) and agree a date for expanded inspection with UK MCA (Paris-MOU). Therefore would strongly recommend to carry out a full FSI with the vessel ready and fully operational, ready to take passengers and prior the Expanded PSC inspection.

Class carrying out extensive inspections and testings. If class satisfied with vessel's condition, vessel can sail for one voyage from Palermo to Southampton estimated on 6 days sea passage to finish with planned works.

Continue as necessary on additional sheets – Additional pages Y N

The original and all copies are to be signed by both the Inspector and Master of the vessel (or by his authorised representative). In addition to prescribed inspections, vessels may be subject to additional follow-up inspections at any time, as deemed necessary by the Malta Transport Authority.

THIS IS NOT A CERTIFICATE OF SEAWORTHINESS, NOR DOES THE INSPECTION RELIEVE ANY PERSON OR ORGANISATION FROM THEIR RESPECTIVE DUTIES AND OBLIGATIONS TO ENSURE THAT THE VESSEL IS MAINTAINED AND MANNED IN A SEAWORTHY CONDITION.

Time started: 11,00 Time ended: 00,00	INSPECTOR'S SIGNATURE:	MASTER'S SIGNATURE:
	NAME, (PRINTED):	NAME, (PRINTED):

SECTION 18 (cont) - ADDITIONAL REMARKS/COMMENTS/DEFICIENCIES

Additional Certificates		Issue Date		Annual		Expiry Date	
Air Pollution		Not issued		Not issued		Not issued	
Sewage		Not issued		-		Not issued	
BUNKER CLC		07.02.12		-		20.02.13	
	Crew List No.	Flag State Endorsement		GMDSS G.O.C. Exp. ✓	Valid Medical Certificate ✓	Tanker/Pass /Ro-Ro Pass Training	Remarks
		No.	Date of Expiry				
Navigation OOW	09	89981	07.11.16	06.11.16	✓	✓	-
Engineering OOW	26	100965	17.06.16	-	✓	✓	See comments

SECTION 3 - Eng OOW no 26 in crew list holds a national COC with two different certificate numbers
 SECTION 3 - Chief Engineer on crew list no. 16 and Eng OOW on crew list no. 46 with copy endorsements only
 SECTION 1 - Vessel currently holds a non-operational certificate of registry valid to 26th April 2012
 SECTION 2 – Certificates issued by Class not issued due to ongoing inspection and pending authorisation from MT.
 SECTION 6 – Following drills need to be carried out on first opportunity: SOPEP, Emerg steering and port side boats manouvered in water.
 Section 7.1 – Magnetic compass deviation card old prior major works hence need to be re-done.-
 SECTION 7.17 – Fire smoke detection system operational but main panel showing fault, pre-warning and disabled.
 SECTION 7.19 – Watertight door panel on bridge with temporary mimic sings on the board.
 SECTION 7.25 – Standing orders not yet posted on bridge and night order book not yet in use.
 SECTION 11 – Crew washing machines in poor condition.
 SECTION 11.8 – A number of light fixtures broken in crew cabin toilets
 SECTION 11.10 – Crew toilets randomly checked. One mirror needs to be properly fixed.
 SECTION 11.18 & 19 – Fire/safety Manuals belong to old company and not updated (CORRECTED)
 SECTION 14.1- Area behind the OWS oily and dirty
 SECTION 14.2 – Bilges oily in places
 SECTION 14.3 – A number of mats missing in way of A/C high voltage
 SECTION 14 – Remote stop fc: emergency generator out of order.
 SECTION 15 – Lifeboat weights found to be heavier than originally told to be. Hence number of persons accommodated on boats reduced and buoyancy/stability of boats cannot be verified by class. Vessel has enough liferafts to cover 100%% of the 370 crew and 20 contractors maintained during this single voyage. All liferafts serviced and up to date.
 SECTION 15.1 – Lifeboat no. 3 with no radar reflector.
 SECTION 15.1 – Lifeboat no. 9 with a crack
 SECTION 15.1 – Lifeboat no. 11 missing.
 SECTION 15.4 – Lifejackets stowed in deck 11 above bridge in poor condition.
 SECTION 16 – One section of the ship is yet not complete and fire equipment is not in place. Such section is said to be closed during the sea passage and attended constantly by fire patrols.
 SECTION 16 – A number of Hi-Fog nozzles dirty and in need of cleaning.
 SECTION 16 – A number of Watertight and fire doors not closing properly (class currently checking)
 SECTION 16 – A number of locations with PA system out of order



Continue as necessary on additional sheets.



Inspector's Signature

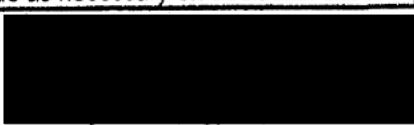

Master's Signature

Extract from *Saga Sapphire's* Safety Management System – Safety Officer – Duties and Responsibilities

POSITION: SAFETY OFFICER
REPORTS TO: MASTER

Duties and Responsibilities:

- Ship's Safety Officer shall report directly to the Master on safety matters. All the operational matters of non-safety content shall be directed to the Staff Captain through to the Captain. The Ship's Safety Officer shall have a good working relationship with the Staff Captain.
- In his role, the Safety Officer shall be supported by the Security Officer in the execution of his duties, as authorised by the Staff Captain.
- The Safety Officer shall be given support from all Head of Departments and request to ensure safety is upheld on the ship. With this in mind all Head of Departments are requested to release manpower to the Safety Officer as and when authorised by the relevant departments.
- The Safety Officer is responsible to the Master for the maintenance of all the fire fighting equipment and lifesaving appliances onboard the vessel. However, to assist in this role, all ship's lifeboats, tenders, life rafts, lifebuoys and embarkation ladders, will be checked by the Deck Officers. All defect lists will be available to the Safety Officer for inspection. The Safety Officer is to ensure that defects found are to be rectified as soon as possible and that any spares required are ordered promptly.
- As the Safety Officer is responsible for the planned maintenance of all fire fighting equipment and lifesaving appliances, he will carry out routine spot checks on all equipment in all areas and all departments of the ship.
- The Safety Officer will ensure, with assistance from the Deck / Engine department, that all expiry dates of all LSA and FFA equipment are not exceeded. He is to ensure that all replacements are ordered and received before equipment expires.
- Ensure that all hazardous materials on board are listed with their stowage and location, and are correctly and securely stowed. He shall ensure that the Chemical Data sheets are displayed in the position of stowage. In this, the Safety Officer will correlate all information and ensure correct stowage, segregation and safety data displays are correct so far as practicable.
- Ensure there are two qualified personnel in charge of each lifeboat and ensure that certificates of all qualified personnel are filed and kept up to date. All files of all crew on board to be kept with the Crew Purser.
- Ensure that the Ship's company receive frequent training and instruction in all areas of safety and fire fighting, boat preparation and other training scenarios.

- In association with the Security Officer/Staff Captain, ensure that frequent fire & Security rounds of the vessel are maintained and the Patrol recorder is operational and in use.
- Provide familiarisation and training to all staff members prior to being assigned shipboard duties in accordance with STCW Section A-VI/1 Item 1, and the issue of muster cards to all newly joined crew.
- The Safety Officer is to carry out regular rounds of all areas of the ship and ensure that all fire escapes and emergency exits are clear, accessible and correctly marked at all times.
- Ensure that the low level lighting strips are all operational and stairway arrows correctly aligned.
- Investigate all passenger and crew accidents and report of the same to the Master and then to Saga Shipping. When carrying out investigations, the assistance of the Security Officer may be required.
- The Safety Officer will investigate all system failures, near misses and incidents, and report his finding initially to the Master who will then forward to Saga Shipping, using the Marine Safety Manager programme. In support of this, the Safety Officer must be supported by all Head of Departments in the pursuit of an open reporting environment, so that all incidents can be investigated openly and fully to benefit the overall safety of the ship.
- Ensure safety training videos are used, and records of attendance kept.
- Ensure that all drills are carried out and attended as per SOLAS requirements and that records of non-attendance are kept.
- Ensure that all Ship's staff are aware and familiar with the ISM code and its function.
- Ensure that all safety documentation and records are kept as per Safety Management System. This is to include, the Code of Safe Working Practices, Watertight door Certification and Tender Coxswain Certification.
- Monitor the regular checks, status and location of all lifejackets.
- Prepare and submit repair requests for safety equipment.
- Maintain and update the Ship's emergency plan and muster list as necessary.
- Ensure lists of crew and passenger check off lists are correctly updated and available at all times.

- Hold a Safety Meeting every month, ensuring that each Department appoints a representative who is able to attend. The Master will chair this Safety Meeting.
- Bring to the attention of Department Heads any breach of the Code of Safe Working Practices.
- Attend and assist with Port State Inspections, as required by the Master and any other survey issues.
- Ensure that the Permit to Work system is adhered to at all times.
- Identify any communication or language problems among the crew members and make the Master aware.
- Record of attendance at all safety and anti-pollution exercises in accordance with Statutory Regulations and Company Procedures.
- The Safety Officer will assist the Deck Department operations as required by the Master e.g. mooring station.
- The Safety Officer is responsible for maintaining the Safety Officer's Record Book, including the daily log and all associated sections. The Safety Officer is responsible for the effective communication to Ship's personnel, of new advice or requirements in relevant shipping legislation, Marine Notices, Company instigated safety procedures and making MAIB reports as directed by the Master via Head Office.
- The Safety Officer is responsible for completing Health & Safety Inspections of each accessible part of the ship at least once every three months. This system is to be completed on a rolling programme, with any deficiencies brought to the attention of the relevant HOD or Line Manager and the Master briefed on completion of the inspection. The Safety Officer should endeavour to complete each inspection accompanied by the Officer or Petty Officer responsible for that area. The Safety Officer is required to make representations and where necessary recommendations to the Master & DPA about any deficiency in the ship in respect of the statutory requirements relating to health and safety, M Notices & Code of Safe Working Practice.
- The Safety Officer has a duty to stop any work which he reasonably believes may cause a serious accident and inform the Master immediately. The Master will then decide when work can safely be resumed.
- The Safety Officer is the Rapid Response Team Leader.
- The Safety Officer is the Rescue Boat Commander and as such will be a suitably qualified Officer with a Deck Certificate of Competency. The Safety Officer will conduct the mooring operation as directed by the Master. The Safety Officer will assist the Staff Captain in the safe and efficient running of the tender operations.

- The Safety Officer shall deputise for the Staff Captain during tender operations when the Staff Captain is indisposed.
- The Safety Officer is to carry out the regular checks in conjunction with the Ship Services Engineer and the Staff Chief Engineer on the Sewage watertight Bulkhead valves and the cross flooding valves.
- Part of your duties will include socialising with the passengers and you will also be required to occasionally host a table in the Restaurant, as required by your Head of Department.
- Assist with shore party duties during tender operations. This is to include driving Ship's tenders, as required, in support of deck ratings.

SIGNATURES

Assignor's Signature
Master

Assignee's Signature
Safety Officer

Extract from *Saga Sapphire's* Safety Management System – Safety Officer's Record Book -
Section 4.5 – Risk Assessments

4.5 RISK ASSESSMENTS

Risk assessment process is an examination of what, could cause harm to people or the vessel. The ship can then weigh up whether they have taken enough precautions or should do more to prevent harm to crewmembers and passengers.

The line managers (Safety Officer, Chief Officer, Staff Chief Engineer, Ship Service Engineer, Chief Electrician, Reefer Engineer, Chief Purser, F&B Manager, Exec Chef, Housekeeper, Assistant Cruise Director) will undertake risk assessments, it is their responsibility to identify and assess all risks within their department. These risk assessments must then be checked and authorised by the heads of departments (Staff Captain, Chief Engineer, Hotel Director, Cruise Director). The Master is responsible for ensuring that this process is carried out on a regular basis.

As a minimum, the following Risk Assessments should be conducted for each vessel:

Deck Department

- Tender Operations
 - Rigging of tender platform
 - Launching of tenders
 - Em/Disbarkation of passengers (alongside)
 - Em/Disbarkation of Passenger (ashore)
- Launching of Lifeboats
- Launching of Liferrafts
- Entry into Enclosed Space
- Working at Height
- Working Overseide
- Diving Operations
- Operation of Splash Doors (Ruby)
- Operation of Water Tight Doors
- Barge Operations
- Mooring Operations
 - Forward
 - Aft
 - Taking a tug Forward
 - Taking a tug aft
- Anchoring Operations
- Helicopter operations
- Rigging of gangway (shore)
- Rigging of gangway (ships)
- Rigging and use of pilot ladders
- Use deck scrubber
- Use of security xray machine
- Use of metal detector archway
- Use of zodiacs
- Use of bosuns chair
- Use of stages
- Use of painting punt
- Use of pressure washer
- Use of derricks/crains
- Painting
- Needle Guns

Technical Department

- Bunkering
- Working on lifts
- Working on Economiser
- Working on boilers
- Repair work on AC compressors
- Working on lifeboat engines
- Working on high voltage equipment
- Working on Generators
- Air filter and belt replacement
- Working on batteries
- Repair of main engine breakers
- Hotwork
 - Welding
 - Cutting
 - Grinding
- Use of power tools
- Use of Hydraulic jacks

Hotel Department

Garbage

- Collection
- Offload of Garbage in port
- Use of glass crusher
- Use of compactor
- Use of pulper
- Use of incinerator
- Offload of garbage at sea

Galley

- Use stockpot cookers
- Use of steam ovens
- Use of fat fryers
- Use of gas BBQ
- Butchering – band saw
- Butchering – meat slicer
- Working in fridges

Resturant

- Carrying of service trays
- Serving of hot foods

Housekeeping

- Collecting and distribution of luggage
- Use of cleaning chemicals
- Use of roller press
- Use of washing machines
- Use of dryers
- Use of irons
- Use of hovers
- Washing of floors



Storing

- Loading stores from ashore
- Distribution of stores internally

Pursers Office

- Use of Visual Display Units

Medical Department

- Carrying of person in stretcher
- Use of stair climber
- Use of X-ray machine

Entertainment Department

- Use of pools
- Use of gym equipment
- Use of massage area
- Use of sauna
- Use of golf simulator

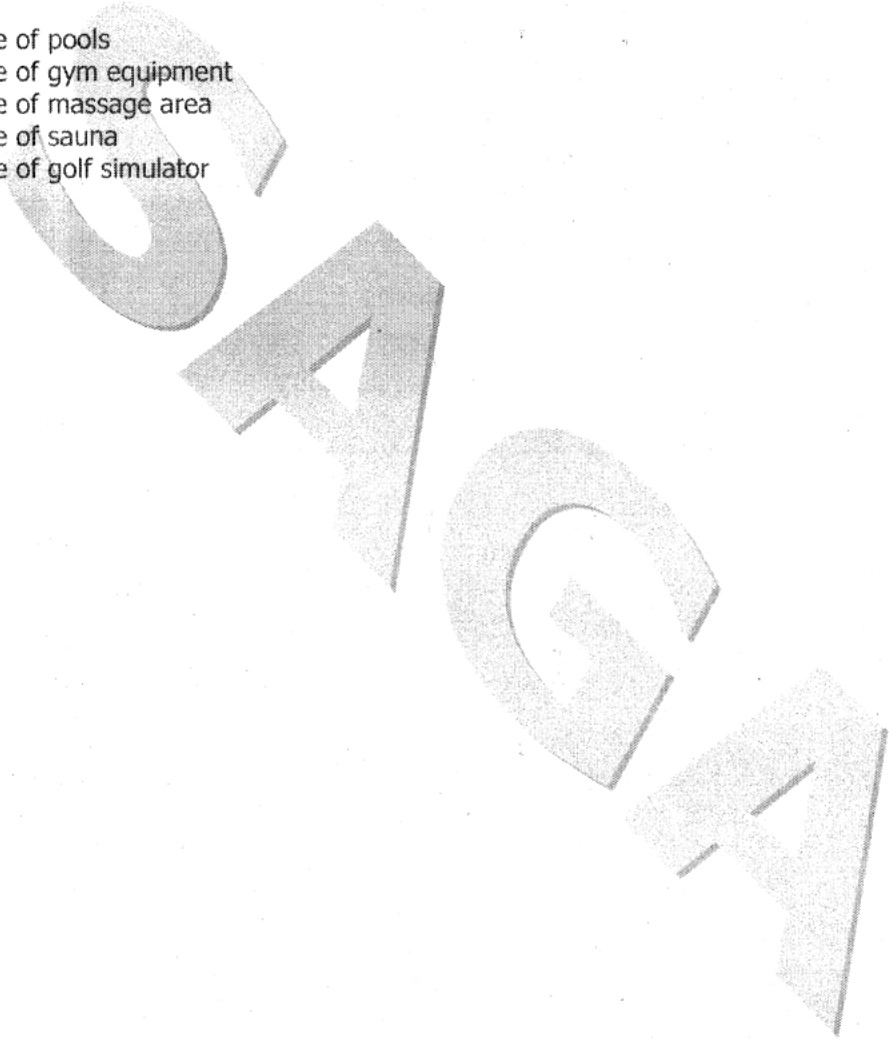



The steps below should be followed for risk assessments:

I. Identify the hazards

When undertaking a risk assessment the assessor(s) should spend time in the area that is being assessed to identify all hazards that may cause harm. Crew that work in that area should be spoken too, as they can have important information. Manufactures instructions and data sheets should be sourced for further information on all equipment used. Long-term hazards should also be thought about during an assessment.

II. Decide who might be harmed and how

Decisions on hazards should be based on groups of people rather than individuals. For each group identifying ways in which they can suffer harm should be undertaken.

III. Evaluate the risks and decide on precautions

The assessor should evaluate and decide ways that crewmembers or passengers can be protected from hazards. It is required that everything that is reasonably practicable should be done where the risk cannot be removed completely. In this case, controlling the risk is the next alternative.

IV. Record your findings and implement them

The Marine Safety Manager software should be used at all times to record the findings of the risk assessment so that it can be shared with the fleet.

V. Review your assessment and update if necessary

Risk assessments should be reviewed and assessed on a regular basis; the review date should be included on any new assessment. Where they are found to no longer reflect the current risks, then a new assessment should be undertaken and the old one updated with findings.

Findings of Risk Assessments shall be recorded in the Marine Safety Manager software. The Line Manager shall

All crewmembers should be aware of the findings of all risk assessments relevant to their work, and may request to read any risk assessments. If the task to be carried out has a risk assessment with significant findings then the persons carrying out that task must be informed before work is started.

For further details on risk assessments, please refer to COSWP Chapter 1.

4.6 ARCHIVING

All forms within this section should be kept for 3 months.

Certificates Checklist (*Saga Sapphire*)

Attachment 8

CERTIFICATES CHECKLIST (Saga Sapphire)
Required for each different Safety Position

		Mandatory Certification														Company Required Training								
		Basic Certification						Advanced Certification																
Man. No.	POSITION	Medical	PST*	Basic Firefighting *	Elementary First Aid*	PSSR*	Crowd Management	Ship Familiarisation	Malta CoC	GMDSS	Deck Watchkeeping Cert II/4	Engine Watchkeeping Cert III/4	ADV Firefighting	CPSC	CMHB	SSO	ECDIS Certificate	Manual Lifting	Safety At Work	Security Team Training	Watertight Door Operator Certificate	Derricks and Winches Certificate	Coxswain's Certificate	Risk Assessment Training
001	Master	X					X	X	X	X					X		X	X*	X*					X
002	Staff Captain	X					X	X	X	X					X	X	X	X*	X*					X
003	Safety Officer	X					X	X	X	X			Xa		X		X	X*	X*					X
004	Chief Officer	X					X	X	X	X			Xa		X		X	X*	X*					X
005	Officer of the Watch	X					X	X	X	X			Xa		X		X	X*	X*					X
006	Officer of the Watch	X					X	X	X	X			Xa		X		X	X*	X*					X
007	Security Officer	X	X		X	X	X	X					Xa		X	X		X*	X*					X
008	Master at Arms	X	X		X	X	X	X					Xa		X			X*	X*	X*				
009	Master at Arms	X	X		X	X	X	X							X			X*	X*	X*				
010	Master at Arms	X	X		X	X	X	X							X			X*	X*	X*				
011	Bosun	X	X		X	X	X	X			X			X				X*	X*	X*	X*	X*	X*	
012	Second Bosun	X	X		X	X	X	X			X			X				X*	X*	X*	X*	X*	X*	
013	Safety Carpenter	X	X		X	X	X	X			X			X				X*	X*	X*	X*	X*	X*	
014	Deck Carpenter	X	X		X	X	X	X			X			X				X*	X*	X*	X*	X*	X*	
015	Quartermaster	X	X		X	X	X	X			X			X				X*	X*	X*	X*	X*	X*	
016	Quartermaster	X	X		X	X	X	X			X			X				X*	X*	X*	X*	X*	X*	
017	Quartermaster	X	X		X	X	X	X			X			X				X*	X*	X*	X*	X*	X*	
018	Quartermaster	X	X		X	X	X	X			X			X				X*	X*	X*	X*	X*	X*	
019	Able Seaman	X	X		X	X	X	X			X			X				X*	X*	X*	X*	X*	X*	
020	Able Seaman	X	X		X	X	X	X			X			X				X*	X*	X*	X*	X*	X*	
021	Able Seaman	X	X		X	X	X	X			X			X				X*	X*	X*	X*	X*	X*	
022	Able Seaman	X	X		X	X	X	X			X			X				X*	X*	X*	X*	X*	X*	

Example copies of the training schedules for weeks commencing 20 and 27 February and
5 and 12 March 2012

Staff Chief Engineer



Ladies and Gentlemen,
Safety Training for week commencing:
Monday 20th February

SAFETY TRAINER

Mon 20th				
Tues 21st	Familiarisation 1	New Crew +Any	09:00	Crew Mess
	Catch-up Fam. 1	Any	18:00	Cabin 5516
Wed 22nd				
Thurs 23d	Familiarisation 2	New Crew +Any	09:00	Crew Mess
	Catch-up Fam. 2	Any	18:00	Cabin 5516
Fri 24th	Familiarisation 3	New Crew +Any	09:00	Crew Mess
	Catch-up Fam. 3	Any	18:00	Cabin 5516
Sat 25th				
Sun 26 th	Familiarisation 4	New Crew +Any	09:00	Crew Mess
	Catch-up Fam. 4	Any	18:00	Cabin 5516

There will be an evening catch-up session at 18:00 for those unable to attend the morning sessions or who have previously missed a session. **A reminder** that all crew must be in possession of Familiarisation Training for the PSSC

Best regards

If you are unable to attend training because of your duties please let me know and other alternative times/dates will be arranged.

Trainer



SAFETY TRAINER

Safety Training for week commencing:
Monday 27th February

Mon 27th	Familiarisation 1	New Crew (Group 1)+Any	14:00	Crew Mess
	Catch-up Fam. 1	Any	18:00	Cabin 5516
Tues 28th	Familiarisation 2	New Crew (Group 1)+Any	09:00	Crew Mess
	Cabin/Area Searchers	As Per Muster List	TBA	Reception
	Stairway/Allyway Guides	As Per Muster List	TBA	Reception
	Catch-up Fam. 2	Any	18:00	Cabin 5516
Wed 29th	Familiarisation 3	New Crew (Group1&2) +Any	09:00	Crew Mess
	Catch-up Fam. 3	Any	18:00	Cabin 5516
Thurs 1st	Familiarisation 4	New Crew (Group 1&2)	09:00	Crew Mess
	Stairway Guides Evacuation Guides	Check crew List on Notice Board Check crew List on Notice Board	15:30 16:30	Reception Reception
	Catch-up Fam. 4	Any	18:00	Cabin 5516
Fri 2nd	Evacuation Guides –Miss-musters		10:30	Reception
	Familiarisation 2	New Crew (Group 2)+Any	14:00	Crew Mess
	Evacuation Control	201 202 203 204 184	15:00	HD Office
	Catch-up Fam. Any	Any	18:00	Cabin 5516
	FIRE TEAM TRAINING FIRE TEAM TRAINING	TEAM A & B TEAM B,C & E	18:30 19:30	Gangway Gangway
Sat 3d	SHIPS DRILLS AS REQUIRED WATCH NOTICEBOARD LISTEN FOR BROADCASTS			
	FIRE TEAM TRAINING FIRE TEAM TRAINING	TEAM A & B TEAM B,C & E	18:30 19:30	Gangway Gangway
Sun 4th	SHIPS DRILLS AS REQUIRED WATCH NOTICEBOARD LISTEN FOR BROADCASTS			

Best regards

If you are unable to attend training because of your duties please let me know and other alternative times/dates will be arranged.

Trainer
Monday 5th March

SAFETY TRAINER



THIS LIST MAY CHANGE AT SHORT NOTICE

Mon 5th	Galley First Response Laundry First Response	All Galley Day Workers All Laundry Day Workers	09:00 10:00	Galley Laundry
	Familiarisation 1	New Crew + Any	14:00	Crew Mess
	Catch-up Fam .1 Any	Any	18:00	Cabin 5516
	Fire Teams A B & C		18:30	
Tues 6th	Familiarisation 2	New Crew +Any	09:00	Crew Mess
	Stairway Guides Evacuation Guides Evacuation Control	EVACUATION EXERCISE	10:00	Reception
	Catch-up Fam. 2		18:00	Cabin 5516
	Fire Teams D & E		18:30	
Wed 7th	Familiarisation 3		New Crew +Any	09:00
	Catch-up Fam. 3	Any	18:00	Cabin 5516
Thurs 8th	Familiarisation 4	New Crew +Any	09:00	Crew Mess
	Catch-up Fam. 4	Any	18:00	Cabin 5516
Fri 9th				
Sat 10th				
Sun 11 th				

Best regards

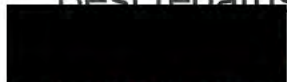

If you are unable to attend training because of your duties please let me know and other alternative times/dates will be arranged.

There will be an evening catch-up session at 18:00 for those unable to attend the morning sessions or who have previously missed a session. **A reminder** that all crew must be in possession of Familiarisation Training for the PSSC

**THIS LIST MAY CHANGE AT SHORT NOTICE
KEEP WATCHING THIS NOTICE BOARD**

Mon 12th	Familiarisation 1	New Crew +Any	09:00	Crew Mess
	BA Refill Party		14:00	BA Compressor Rm.
	Catch-up Fam. 1 Any	Any	17:30	Cabin 5516
	CREW DRILL		18:30	
Tues 13th	Familiarisation 2	New Crew +Any	09:00	Crew Mess
	Watertight Door Operators		10:00	Hospital
	Lifeboat Preparation Teams		13:00	
	Catch-up Fam. 2 Any	Any	17:30	Cabin 5516
	CREW DRILL		18:30	
Wed 14th	Familiarisation 3 Any	New Crew + Boat Working Party	09:00	Crew Mess
	Soul Counters		14:00	Reception
	Catch-up Fam. 3 Any	Any	17:30	Cabin 5516
	CREW DRILL		18:30	
Thurs 15th	Familiarisation 4	New Crew + Boat Working Party	09:00	Crew Mess
	Catch-up Fam. 4 Any	Any	17:30	Cabin 5516
	CREW DRILL		18:30	
Fri 16th	Team Training as Required		10:00	Reception
	Catch-up Fam. Any Module	Any	17:30	Cabin 5516
	CREW DRILL		18:30	
Sat 17th	Team Training as Required		10:00	Reception
	Catch-up Fam. Any Module	Any	17:30	Cabin 5516
	CREW DRILL		18:30	
Sun 18 th	Team Training as Required		10:00	Reception
	Team Training as Required		10:00	Reception
	CREW DRILL		18:30	

Best regards

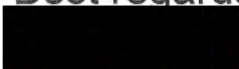

If you are unable to attend training because of your duties please let me know and other alternative times/dates will be arranged.

Acromas Shipping Ship Familiarisation Certificate for the first cook

Acromas Shipping

Certificate
020312-28

SHIP FAMILIARISATION CERTIFICATE

This is to certify that the person named below has been given a familiarisation talk by their Head of Department and attended the four modules of a Ship Familiarisation Course. In addition, they have successfully completed a Ship Familiarisation Safety Test onboard an Acromas Vessel. The candidate has shown to be conversant with his/her safety duties, familiar with ships safety & survival equipment, with the Merchant Navy Codes of Conduct and ISPS, Company Working Practices concerning MARPOL & the ISM Code.

FAMILIARISATION BY DEPARTMENT HEAD:
AS PER SEC26 - ATTACHMENT 1 (SEE REVERSE OF THIS CERTIFICATE)

MODULE 1*
Emergency telephone no. Muster List & Emergency Duties, Emergency Broadcasts & Responses. Donning of a Lifejacket, Watertight doors & Splash Doors (Ruby) (theory & practical), Ship tour & placement at Emergency Station & Boat or Raft Station

MODULE 2
Fire Awareness, Fire Fighting Equipment, Evacuation Procedures, Evacuation Routes, Fire Prevention

MODULE 3
Lifeboats, Life-rafts, Sea survival equipment, First Aid, Medical & Sanitary Information

MODULE 4
Ship security, Code X-ray procedures, ISPS for those without security duties, Security Threat Assessment Levels, Merchant Navy Code Of Conduct, Disciplinary procedures, MARPOL & ISM Code

COURSE COMPLETION
Familiarisation Safety Test pass

[Redacted] *To be completed on the day of joining vessel, prior to the vessel sailing

[Redacted] *To be completed on the day of joining vessel, prior to the vessel sailing

[Redacted]

[Redacted]

[Redacted]

[Redacted]

Course Completion Date

9/3/12

Name

B13194S

Seaman's Discharge Book

Candidates
Signature

Safety Officer
Signature

SHIPPING
TRAINING OFFICER

MAIB's Safety Study 1/2001 – Review of Lifeboat and Launching Systems' –
Section 2.2 – Bowsing and Tricing

2.2 BOWSING AND TRICING

Of the ten accidents reported involving bowsing and tricing, one resulted in two fatalities, and five in injury.

2.2.1 Operational

If a lifeboat is not to be boarded in the stowed position, it must be capable of being held in to the side of the vessel for safe embarkation. This is achieved conventionally by the sequential use of tricing pennants and bowsing tackles.

Launching procedures call for the lifeboat to be lowered to embarkation level while the tricing pennants pull it into the side of the vessel (**see Figure 5**). Once at the correct level, bowsing tackles are secured between the forward and aft lower blocks and the ship (**see Figure 6**). When tightened they take over the function of the tricing pennants, which are then disconnected.

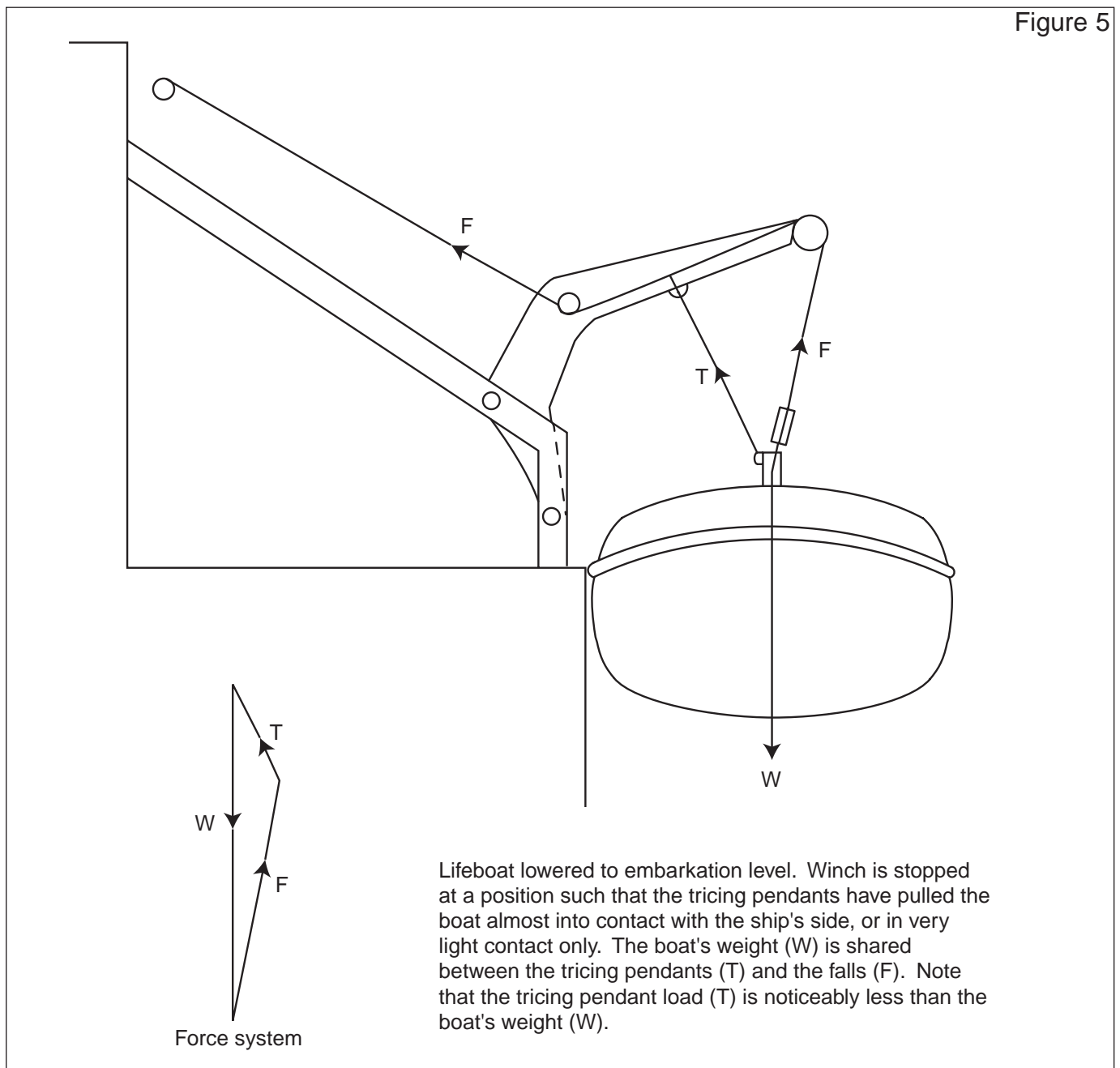
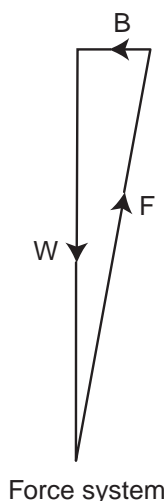
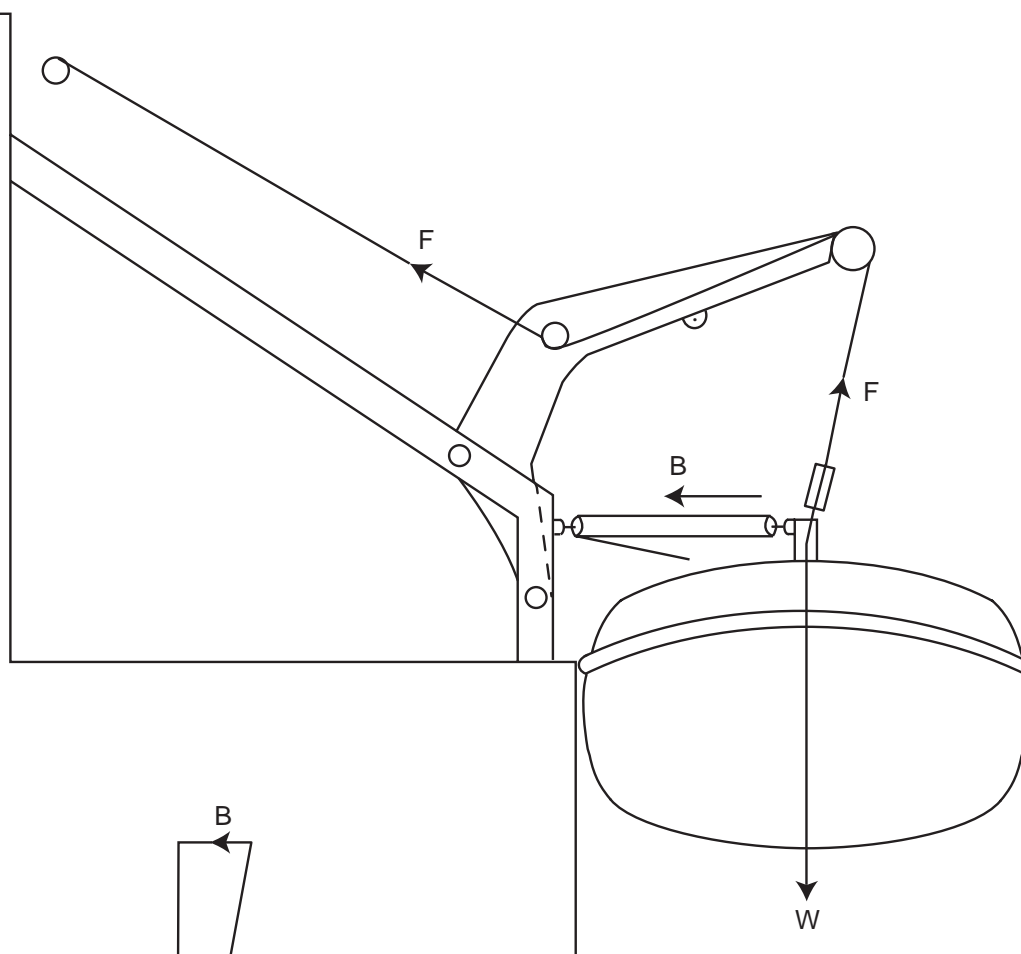

Figure 6



Force system

Lifeboat lowered to embarkation level, triced in and the bowing tackles fitted. Once tricing pendants are slipped, properly tensioned bowing tackles retain the lifeboat into the ship's side. Because the bowing forces are virtually horizontal, only the falls load (F) supports weight (W), as intended. Also, F is acting in the back falls and contributes to the support of the davit arms.

This process can be time-consuming while the bowing tackles can be heavy and awkward to handle, particularly on high capacity lifeboats. Investigations have shown that the full bowing-in procedure is often ignored during crew exercises.

When the lifeboat carries only its launching crew, holding the lifeboat to the side of the vessel with just the tricing pennants can be achieved with relative ease, and causes no serious problem. Attempting the same procedure with a fully or, indeed, partially laden boat is potentially dangerous. A number of accidents have occurred as a result.

In most exercises the lifeboats are rarely fully loaded, and the need for rigging bowing tackles is often ignored, particularly if the boat is to be returned to its stowed position

immediately afterwards. Such a procedure then becomes the normal practice, and the correct techniques are either ignored or forgotten, with launch crews viewing the bowsing tackles as cumbersome and an unnecessary nuisance.

Bowsing tackles have an important role to play to bring the lifeboat plumb on its falls. With the lifeboat triced into the embarkation position it becomes necessary to transfer the load to them. Many accident investigations, however, reveal a variety of shortcuts and unsafe procedures that result in injuries.

There is evidence to show that some crews do not rig the bowsing tackle, but choose instead to let go the tricing pennants by releasing the senhouse slips. This, at best, results in a lifeboat swinging out from the ship's side in an uncontrolled fashion and injuring those embarked, sometimes seriously. Unless the lifeboat's crew are safely secured, they may be injured by the sudden movement, or lose their balance and fall over the side. The risk of this happening is high, particularly if any of the crew is on the lifeboat's canopy to gain access to the tricing pennants' senhouse slips.

Properly rigged and tensioned bowsing tackles remove the loads from the tricing pennants before they are slipped. By gradually paying them out, the lifeboat can be controlled to reach the plumb condition so that undesirable and potentially dangerous swinging is avoided. This is the procedure that properly trained and disciplined seafarers or lifeboatmen are expected to follow, and one of increasing importance if the vessel is developing a lowside list.

Because so many exercises do not involve lowering the lifeboat into the water, the decision is often taken to dispense with the bowsing tackles altogether, and continue with the tricing gear alone. What starts as a convenient measure develops into accepted practice which may well lead to injuries in training or drills or, worse still, the procedure to be used in an emergency.

A second potential danger of not bowsing in a lifeboat is that a loaded lifeboat might overload the tricing pennants. If they fail (**see Figure 7**), the consequences can be serious. This is likely to occur if the lifeboat is brought hard against the ship's side. It can even lead to the falls going slack if the winch wire is paid out too far. Tricing pennant failure would again cause the boat to swing uncontrollably, endangering anyone who happened to be embarking at that particular moment.

Failure of a single tricing pennant with slack falls has been known to have serious implications. When continuous falls are fitted, they will run out at the end where the failure has occurred. The lower block at the other end will simultaneously rise, sometimes sufficiently far and hard to hit the head of the davit arm. This imposes a dynamic overload on it and may lead to failure with the consequential repercussions for anyone in the lifeboat. This seemingly unlikely train of events has occurred in one boat where the crew was testing experimental tricing/bowsing gear (**see Figure 8**). It was a serious accident and people were killed.

The MAIB has received reports of tricing pennants failing in some vessels, and the crews being persuaded to increase the pennant strength to prevent a repetition. In the MAIB's opinion this further encourages the crew to retain tricing pennants in exercises, rather than use the bowing tackles.

Figure 7

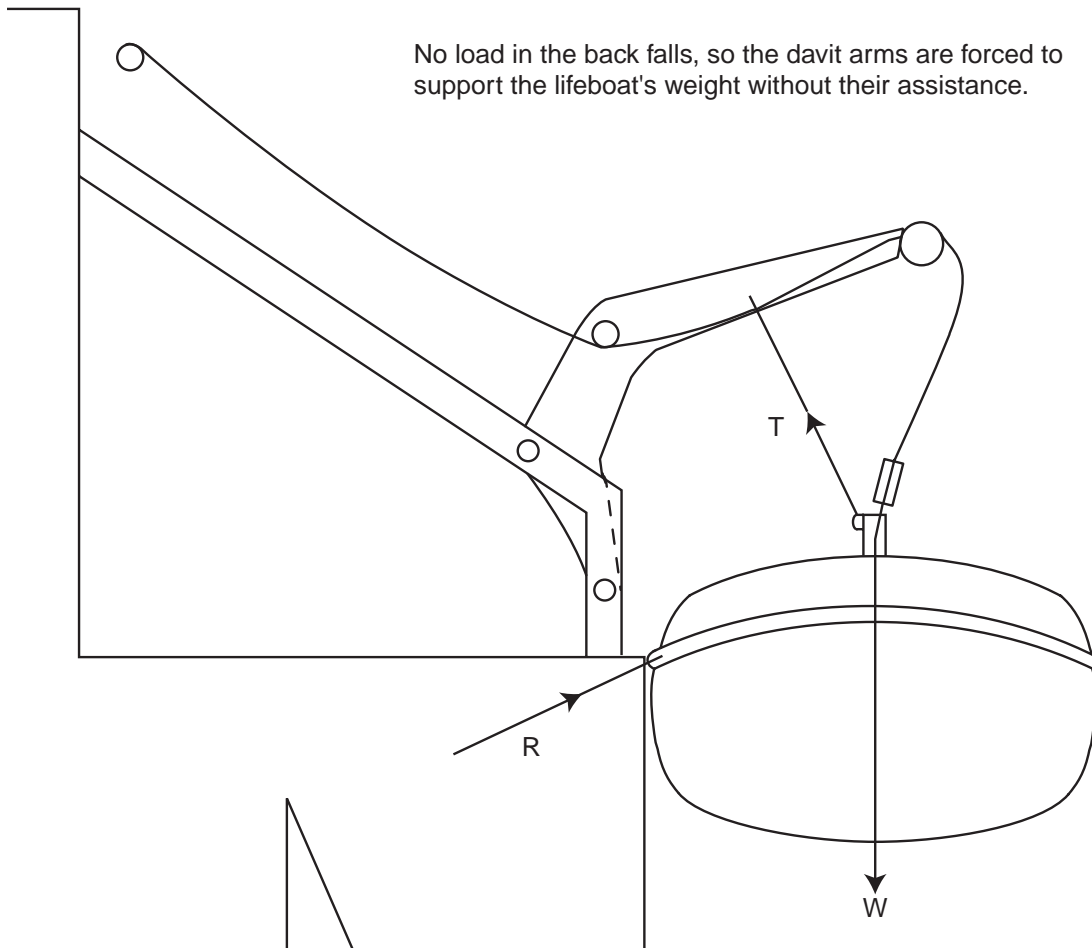

No load in the back falls, so the davit arms are forced to support the lifeboat's weight without their assistance.

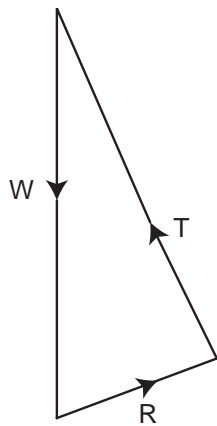

Force system

Lifeboat lowered to embarkation level. However, winch is allowed to run to the extreme position where the falls become slack. The boat's gunwale is in heavy contact with the ship's side. The tricing pendants now take the boat's weight (W) alone and their loading is much increased. A load that they are rarely designed to take.

Figure 8

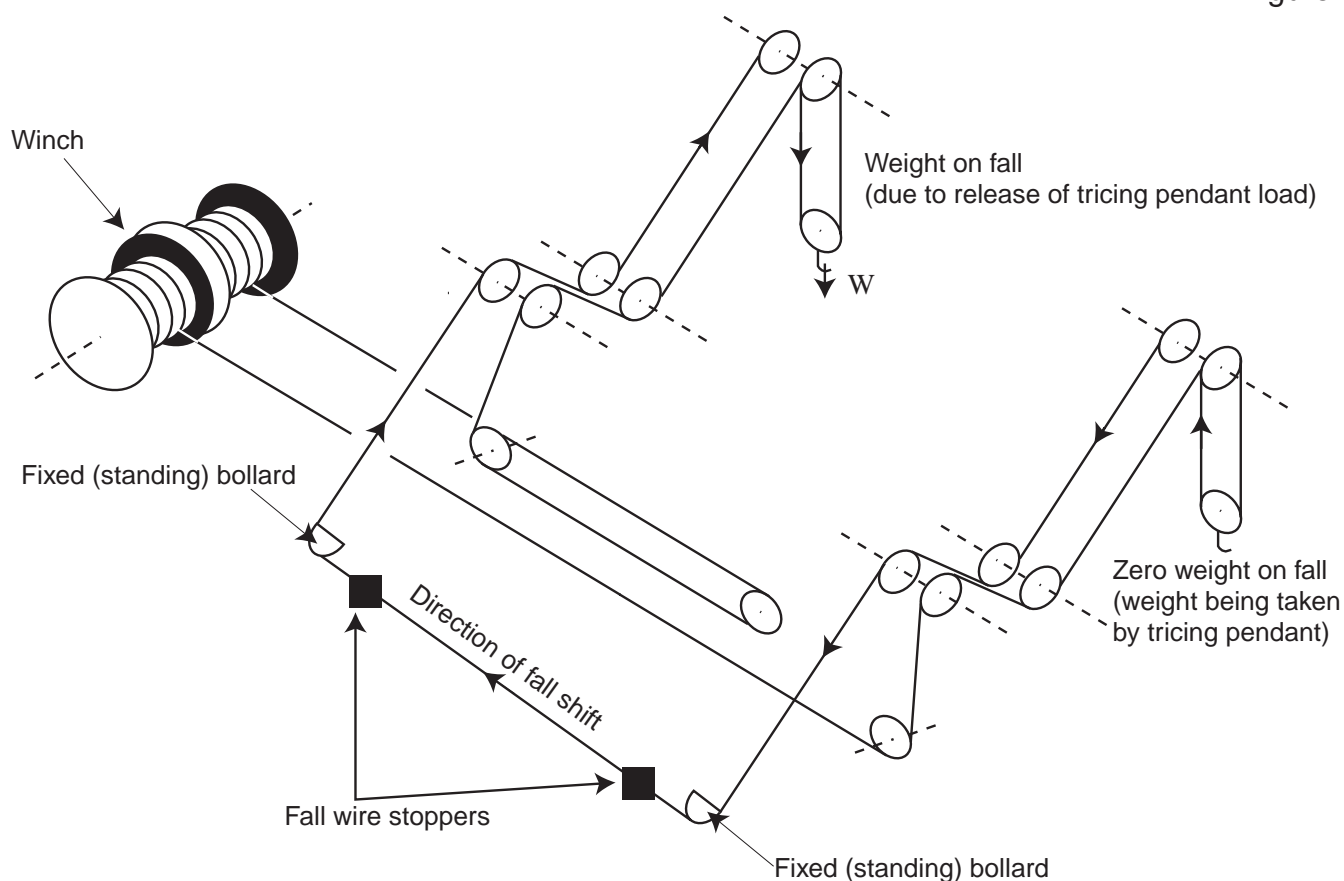

When lowering the boat to embarkation level, the winch might be payed out so far that the falls go slack. Only the tricing pendants then take the boat's weight. Should one tricing pendant then fail, or is slipped, the weight at that end attempts to transfer to the falls. However, as there is no weight on the falls at the other end, because the remaining tricing pendant is still taking it, they can offer no balancing reaction. They then have a tendency to shift or slide towards the end where the tricing pendant has failed. This tendency is normally resisted by friction between the falls and the standing bollards. But, again, without load in the falls no significant friction force can be generated.

The shift may be sudden and might not be resisted by the fall wire stoppers.

2.2.2 Design

A further consequence of not properly bowing in a lifeboat can occur if the load bearing capacity of the davit arms is dependent on support offered by the back falls which lead inboard from the davit heads (**see Figure 9**). With the lifeboat at embarkation level, and supported by falls and tricing pennants, its weight is shared between them. The greater the proportion of weight taken by the tricing pennants, the less will be taken by the falls. This gives a corresponding reduction in the load on the back falls, which means that their contribution to supporting the davit arm is reduced. This results in an increased portion of the load being taken on the supporting structure of the davit arm and can, on some designs, overload it if the boat is fully laden (**see Figure 10**).

Figure 9

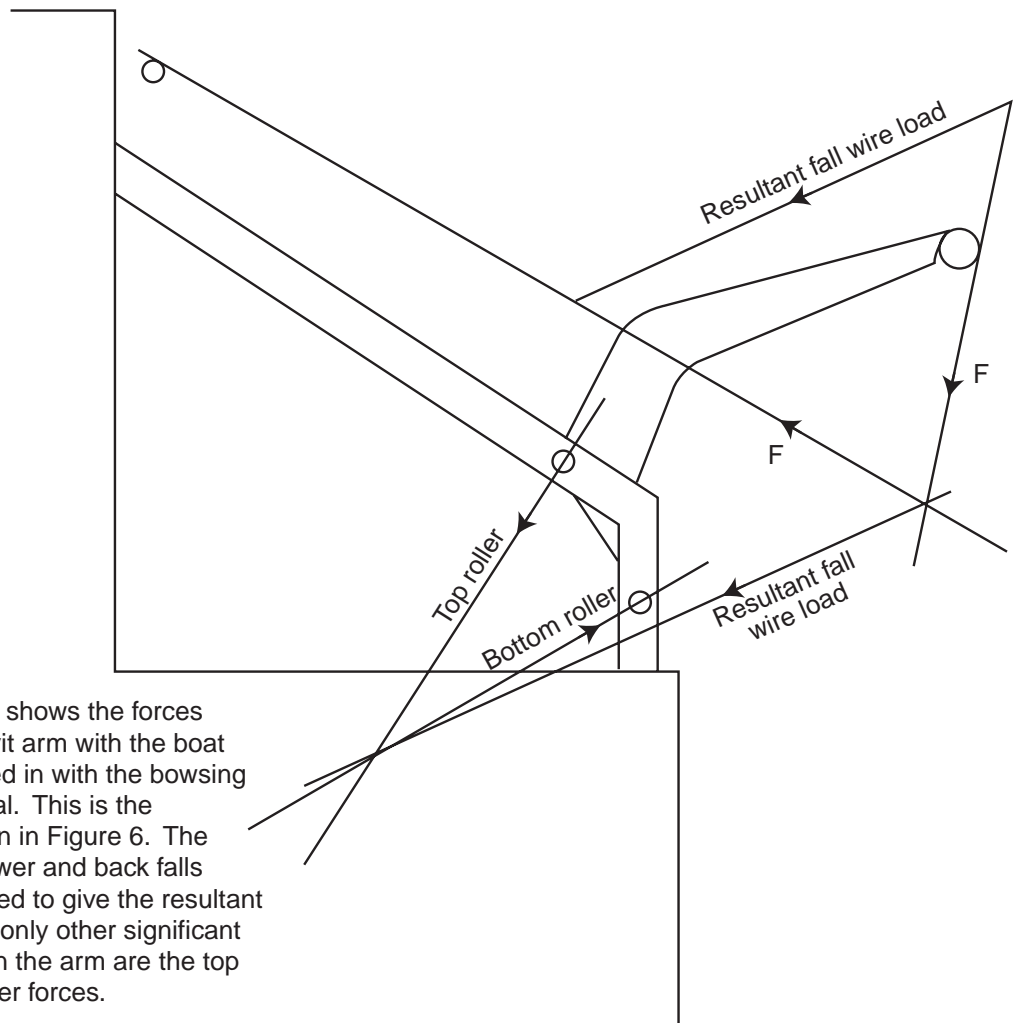

Above diagram shows the forces acting on a davit arm with the boat properly bowsed in with the bowsing tackle horizontal. This is the condition shown in Figure 6. The forces in the lower and back falls have been added to give the resultant wire load. The only other significant forces acting on the arm are the top and bottom roller forces.

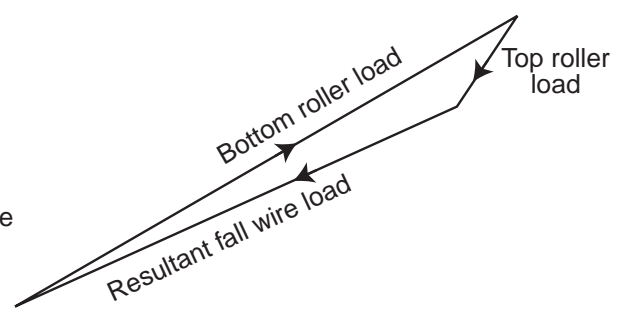

The diagram to the right is the above force system giving the relative magnitudes of the forces.

Figure 10

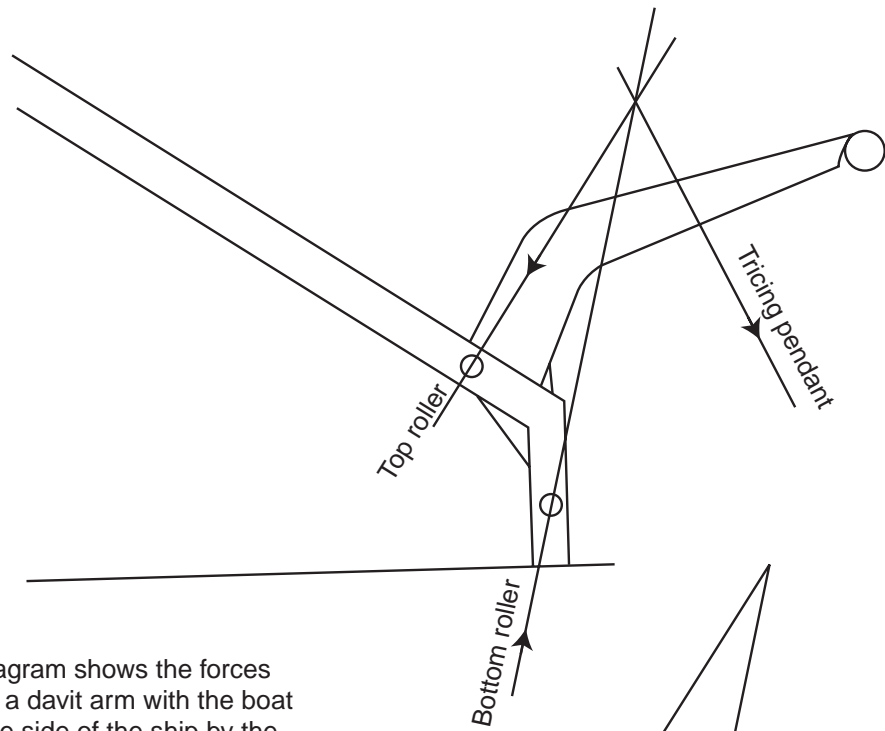

Above diagram shows the forces acting on a davit arm with the boat held to the side of the ship by the tricing pendants and with the falls slack. This is the condition shown in Figure 7. The only significant forces acting on the arm are the tricing pendant load, the top and bottom roller forces.

The diagram to the right is the above force system giving the relative magnitudes of the forces. Notice how much greater are the roller loads compared to the properly bowed in condition of Figure 9.

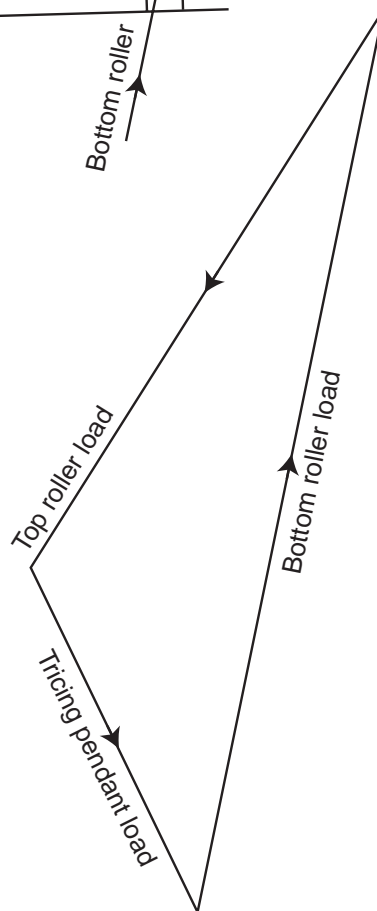

In this context it should be noted that bowsing tackles, in contrast to tricing pennants, are normally arranged so that when fully rigged, they are close to the horizontal. Tricing pennants are usually much nearer to the vertical, and therefore take a greater proportion of the boat's weight. This geometry ensures that properly rigged bowsing tackles are unable to support any significant component of the boat's weight, so make no significant reduction to the load on the falls.

This critical feature has led to one total failure of a davit arm during an overload test. The surveyor failed to recognise the contribution made to the davit arm's support by the back fall load. He agreed to the test load being supported directly from the davit head, rather than being applied to the hook and lower block. On application of the test load, the davit arm was torn from its trackway. Fortunately since it was a test, nobody was in a position to be injured, but it demonstrates how important the support of the back falls load can be in some designs.

Ship's crew can rarely identify whether back fall loads are critical features of a davit design. Such information is normally the preserve of the designer or those who have carefully analysed the design. Those who actually operate the systems do not, in practice, need such detailed knowledge providing they routinely follow the correct tricing and bowsing which will eliminate any possible danger.

The examples of failures stemming from the incorrect use of tricing pennants, and the difficulties found in using bowsing tackles, raises the question as to whether they are still necessary.

They were first introduced in days when lifeboats tended to be relatively small, light and open. Over the years lifeboats have become increasingly larger and heavier, and many are now enclosed. Both tricing pennants and bowsing tackles have, however, been retained with their strength being simply increased in proportion to the increased weight. The increased size and weight of many modern lifeboats has further implications: an increase in manual effort for the crew.

Some owners and equipment manufacturers have recognised these shortcomings in exercises. Many of the problems are operational, but by the time the system has been selected, installed and commissioned, it is too late to do anything other than make comparatively minor, non-structural, changes to improve matters. Solutions to the known problems of trying to hold in a large heavy boat have usually been solved by designing a combined tricing and bowsing gear operated by a winch.

Some equipment manufacturers have rethought the entire concept, and have designed new types of launching systems which have totally dispensed with tricing and bowsing systems. Although the costs are higher than many more traditionally based systems, the design philosophy appears to be worth close scrutiny by the industry.

As part of its study, the MAIB attempted to gauge the industry's reaction to such a development, and soon detected a difference of opinion. On the one hand there are

designers attempting to market systems which they consider to be better and safer than those currently in use. On the other, there are shipowners who are not only concerned by the additional costs involved, but have reservations about the risks of introducing an untried system. They are also concerned about the possibility of having to modify or change it after installation to ensure that it works properly.

Some shipowners are also influenced by the international regulatory system, and the need to satisfy the requirements of SOLAS. While a laudable attitude at face value, it ignores the reality that these standards are minimum requirements and can be exceeded.

2.2.3 Maintenance and repair

MAIB's database has insufficient information to allow an analysis to be made of the effectiveness of maintenance and repair regimes for tricing and bousing gear. activity, including the starting of engines. They can be avoided.

Manufacturer's Training and Operating Instructions for Lifeboat Davits – To Launch for Lifeboat Operations

TRAINING AND OPERATING INSTRUCTIONS FOR LIFEBOAT DAVITS

The boats 1+2 are rated as Lifeboat davits for 88 persons lowering and for 4 persons hoisting. The boats 3-6 are rated as Lifeboat Davits for 120 persons lowering and for 4 persons hoisting.

The boats 7-10 are rated as Tender / Lifeboat Davits for 90 persons lowering and for 4 persons hoisting.

The boats 11+12 are rated as Rescue / Lifeboat Davits for 44 persons lowering and for 6 persons hoisting.

For evacuation operations the boats are launched by gravity with control of the winch brake from the deck. The boat is manned in the outboard position and launched to the water in one continuous operation.

It is also possible to operate the winch on deck, and by remote control wire if any designed.

TO LAUNCH FOR LIFEBOAT OPERATIONS

1. Ensure that the winch hand-brake is in the fully closed position, that the maintenance locking bars are not inserted in the davit stands and that the crank handle is not on the winch shaft.
Maintenance locking bars are not part of the davit system but part of the deck maintenance crews equipment. They must be used only during overhaul of the davits and winches and at not other time must they be left in position, particularly when the ship is at sea.
2. Crew (survivors) embark boat and fasten bowing blocks and lines.
3. Release craft gripes with the aid of their slip hook, the gripe lines will clear craft automatically.
4. Operator opens winch dead-man brake by pulling control lever on winch.
During the swinging out the load on the winch increases until the davits are in the full outboard position. Unnecessary braking should be avoided to prevent the boat from swinging and hitting the ship's side.
5. Embark all passengers.
6. Release tricing pendants with the aid of their slip hook if any.
7. Release bowing lines from the bollard of the bowing blocks, remove the blocks from plate link of boat suspension.
8. Lower away to the water by maintaining the winch brake control lever or wire.
9. Do not apply the brake immediately the boat is waterborne but let the winch run on so as to give slack to facilitate unhooking the lower blocks.
10. After releasing the lifting hooks the helmsman steers the boat away from the vessel.

mv *Saga Sapphire* - LSA Training Manual and Survival Techniques –
Chapter 7 Protection in Launching Areas – new Section 7.4 - Use of Safety Harnesses When
Preparing Lifeboats

CHAPTER 7

PROTECTION IN LAUNCHING AREAS

- 7.1 PROTECTION ON DECK
- 7.2 OUTBOARD HAZARDS
- 7.3 LIGHTING AT SURVIVAL CRAFT LAUNCHING STATIONS
- 7.4 USE OF SAFETY HARNESSSES WHEN PREPARING LIFEBOATS

Written By: [REDACTED]

1st uncorrected copy. Positions, items and equipment may change as vessel is accepted into the Saga Fleet

7.1.1 PROTECTION ON DECK (IN THE LAUNCHING AREA)

All lifeboats and life-rafts are boarded via opening gates in the Ship's side rails (See Fig: 1).



Fig: 1 – Embarkation gates for lifeboats

Written By: [REDACTED]

1st uncorrected copy. Positions, items and equipment may change as vessel is accepted into the Saga Fleet

7.2 OUTBOARD HAZARDS

When launching the Lifeboats, the davits should be deployed fully in order to ensure that the boats clear the sky rail on either side of the Ship.

There are no overboard discharges that will effect the launching of the survival craft.

In the event of a heavy list being apparent, it is important to remember that the lifeboats should not be launched from the high side without first confirming that the stabilisers have been retracted. Should the stabilisers still be extended then the launching of Lifeboats on the “high side” will not be interrupted but the “out” stabilisers must be considered as an extra hazard.



The controls for the stabilisers are situated on the Bridge.

7.3 LIGHTING AT SURVIVAL CRAFT LAUNCHING STATIONS

Lighting for survival craft launching stations and the operation of these is covered on Section 6.2 Emergency lighting.

7.4 USE OF SAFETY HARNESES WHEN PREPARING LIFEBOATS



When launching lifeboats and tenders, it is typically necessary for the crewmembers designated to operate the bousing in tackle and tricing in pendants to either lean outboard, or climb completely outboard of the boat.

For this reason it is a requirement for each of these crewmembers to wear a safety harness when boarding the boat to carry out their duties. Whenever they are climbing outboard or leaning outboard of the boat each crewmember should ensure they are secured to a fixed part of the lifeboat.

The safety harness should be worn in conjunction with all other PPE typically required and should be worn beneath the crewmembers lifejacket.
